

230 SERIES

FOUR FINGER CONTACT CLIPS

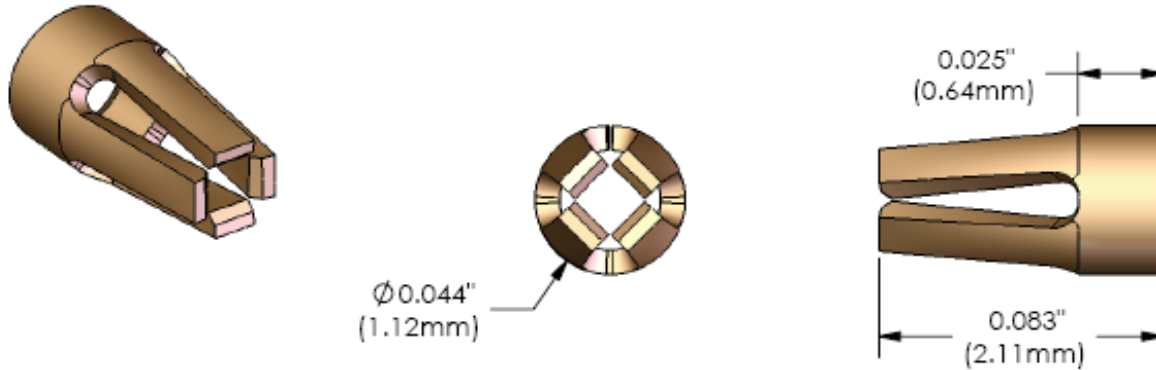

TECHNICAL PRODUCT DATA

WEISS-AUG PART NUMBER	CLIP TYPE	TEST PIN DIAMETER	OPERATING RANGE PIN DIAMETER	MAXIMUM INSERTION FORCE	MINIMUM WITHDRAWAL FORCE	MATERIAL
1-2-3001-23001	230	0.017" (0.432mm)	0.015" - 0.023" (0.38mm - 0.58mm)	250g	50g	C17200
1-2-3001-23002	230L	0.017" (0.432mm)	0.015" - 0.021" (0.38mm - 0.53mm)	150g	50g	ALLOY #174
1-2-3001-23003	230SL	0.017" (0.432mm)	0.015" - 0.021" (0.38mm - 0.53mm)	60g	25g	C17200
1-2-3001-23007	230H	(SEE NOTE 5)	0.015" - 0.023" (0.38mm - 0.58mm)	450g	50g	C17200

NOTES:

1. ALL FORCE DATA RELATES TO UNPLATED CLIPS.
2. TESTS PERFORMED WITH POLISHED STEEL BULLET NOSE PINS.
3. 230, 230SL, AND 230H MANUFACTURED FROM BeCu ALLOY C17200 1/2 HARD MATERIAL, HEAT TREATED POST FORMING.
4. 230L MANUFACTURED FROM ALLOY #174
5. 0.021" TEST PIN USED TO CHECK INSERTION FORCE; 0.017" TEST PIN USED TO CHECK WITHDRAWAL FORCE.

SUFFIX DEFINITIONS: "L" = LOW FORCE "SL" = SUPER LOW FORCE "UL" = ULTRA LOW FORCE "H" = HEAVY FORCE



WEISS-AUG

Precision Manufacturing by Innovative Design
Stamping, Insert Molding and Assembly

220 Merry Lane • East Hanover, NJ 07936 • USA

T. 973.887.7600 • F. 973.887.8109 • www.weiss-aug.com



QUALITY IS OUR
BUSINESS

